

## 5V IN-LINE REGULATOR FOR ACTION MICRO-PROCESSOR UNITS

# P99

A number of modellers prefer to use a 5-cell rechargeable NiMH pack or 6V sealed lead-acid battery to power the receiver and other electronic devices in their models. This gives the servos extra power and speed. Unfortunately a fully-charged battery or pack of this capacity can exceed 7.5V, which will damage or destroy the micro-processors which are the basis of many ACTION speed controllers, switches and sound units. This

simple In-Line regulator will take the power from the receiver battery and reduce it to a "friendly" 5.0V, allowing the servos etc to benefit from the full battery voltage without damaging the ACTION unit. The maximum current which can be carried by P99 is 100mA. The unit simply plugs into the appropriate channel output socket of the receiver, while the ACTION unit is plugged into the female socket on the other side of the P99.

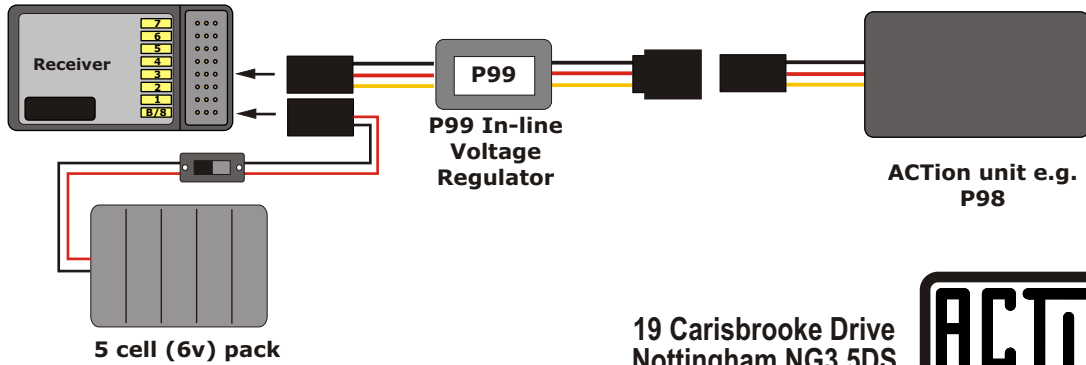

19 Carisbrooke Drive  
Nottingham NG3 5DS  
United Kingdom



© Action R/C Electronics

+44 (0) 115 9607951

## P99 5V IN-LINE REGULATOR

Kit version - Building sequence

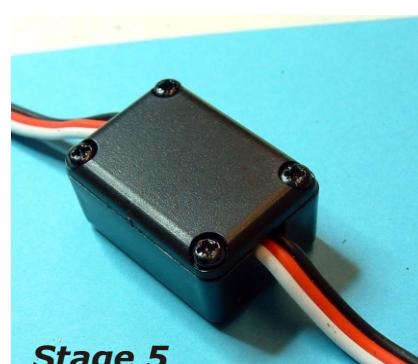
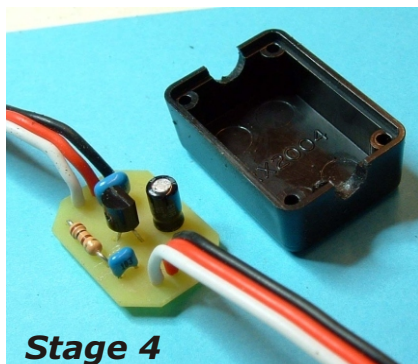
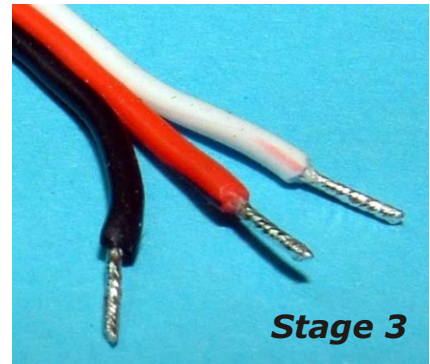
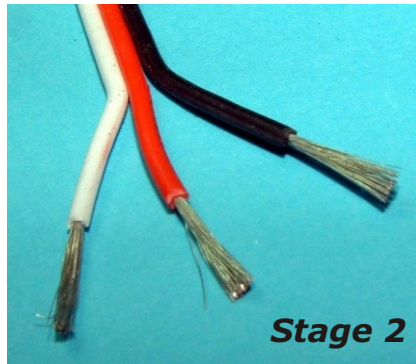
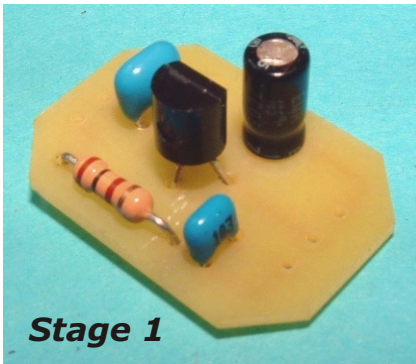

**P99  
KIT**

**KIT ASSEMBLY DRAWINGS**

**ACTiON**  
R/C ELECTRONICS

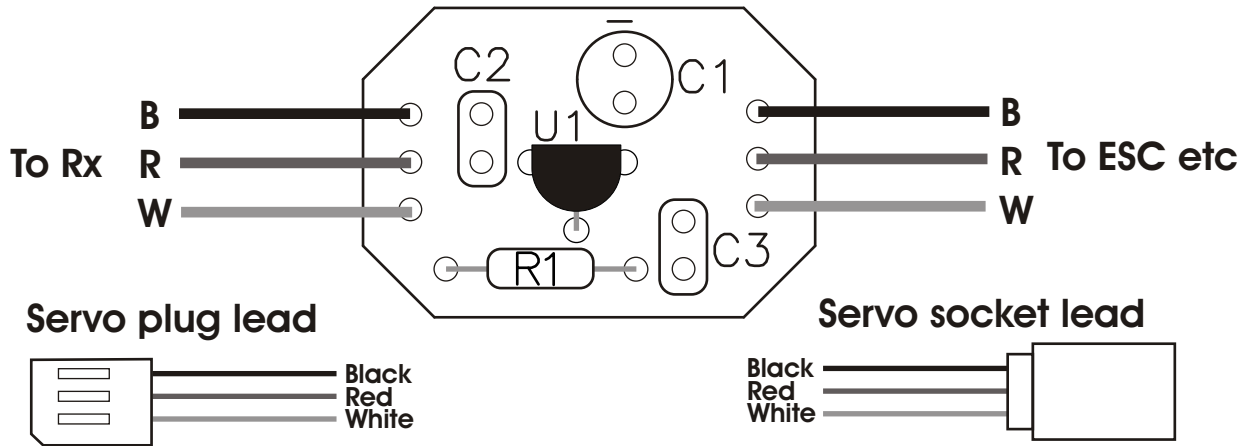

**COMPONENT LAYOUT**

**Parts List**

- U1** LE50CZ
- C1** 2.2uF 50V
- C2** 0.1uF Mono 104 Blue
- C3** 0.01uF Mono 103 Blue
- R1** 100R 1/4W
- Case** Rx 2004 + Screws
- PCB** P99
- Leads** Futaba 200mm Extension (Cut 100mm each M & F)

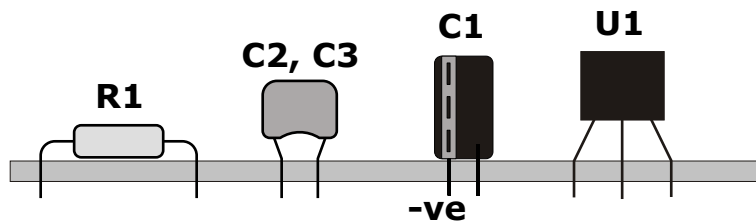

**COMPONENT MOUNTING DETAILS**

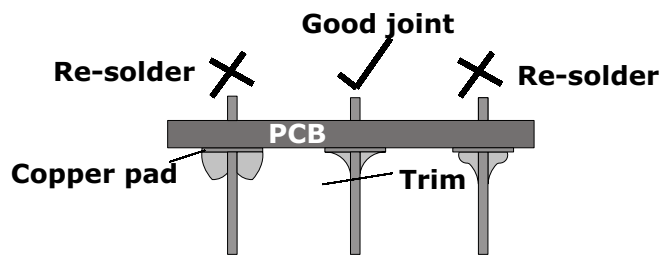

**SOLDERING TIPS**

## **P99 Kit Instructions**

There is a five-stage photographic assembly sequence of this unit on our website. The link is [www.action-electronics.co.uk/pdfs/P99.pdf](http://www.action-electronics.co.uk/pdfs/P99.pdf)

### **PCB**

The Printed Circuit Board (PCB) for this Project is fully prepared and requires no additional work.

### **TOOLS**

For construction you will require a soldering iron and flux cored solder (we recommend 22SWG), a screwdriver and a small pair of wire cutters. You also require a good level of light in which to work.

### **PARTS**

There are only five parts in this kit, apart from the PCB and case; a 5v 100mA regulator IC, a resistor, a small electrolytic capacitor and two monolithic capacitors.

### **CONSTRUCTION**

Fit U1 first, bending the leads as per the drawing; ensure that the flat part faces towards capacitor C1.

Now fit the capacitor C1, which is electrolytic and must be fitted the correct way around i.e. with the pale band marked with negative (-) signs to the outside of the PCB as shown.

Next, fit the resistor R1 it can be fitted either way around.

Fit the two small blue monolithic capacitors C2 and C3. C3 is the smaller of the two and is marked 103, while the larger C2 is marked 104. Again, they can be fitted either way around.

Check the rear of the PCB to ensure that there are no solder bridges and the PCB is correctly soldered. Crop off any surplus leads flush with the soldered joints. This completes construction of the printed circuit board. See Stage #1.

Cut the extension lead supplied into two equal lengths. Strip approx 8mm of insulation from the ends of the wires; twist the strands together and tin them with solder. Crop off the ends approx 3mm. See Stages #2 and #3.

Insert the wires from the plug lead into the LH end of the circuit board as shown; make sure you fit them into the correct holes, then solder on the underside of the board and crop off the surplus lead. Repeat for the leads from the socket. See Stage #4.

Clean off the rear of the PCB with a spirit cleaner and brush (an old toothbrush is ideal) to remove all the solder flux.

File two slots into the top edge of the case to permit the two leads to exit without being crushed by the lid, then fit the completed unit into the case and screw down the lid. Stage #5.

### **TEST**

Simply connect the plug lead to your receiver and the socket lead to your speed controller or switcher.