

BASIC TWIN MOTOR INSTALLATION WITH BOW THRUSTER, USING P94 DUAL ESC/MIXER UNIT

Alternative motors (2 required) with 12v battery :

- Mabuchi 555*
- Torpedo 500 geared 6:1 (shown)*
- ACTION 755*
- Graupner Speed 720 Torque
- ACTION 900*

With 6.0 - 7.2v battery:

- Mabuchi 555*
- Low-drain 540* or 545 generic
- Torpedo 500 geared 2.5:1*

*Available from ACTION

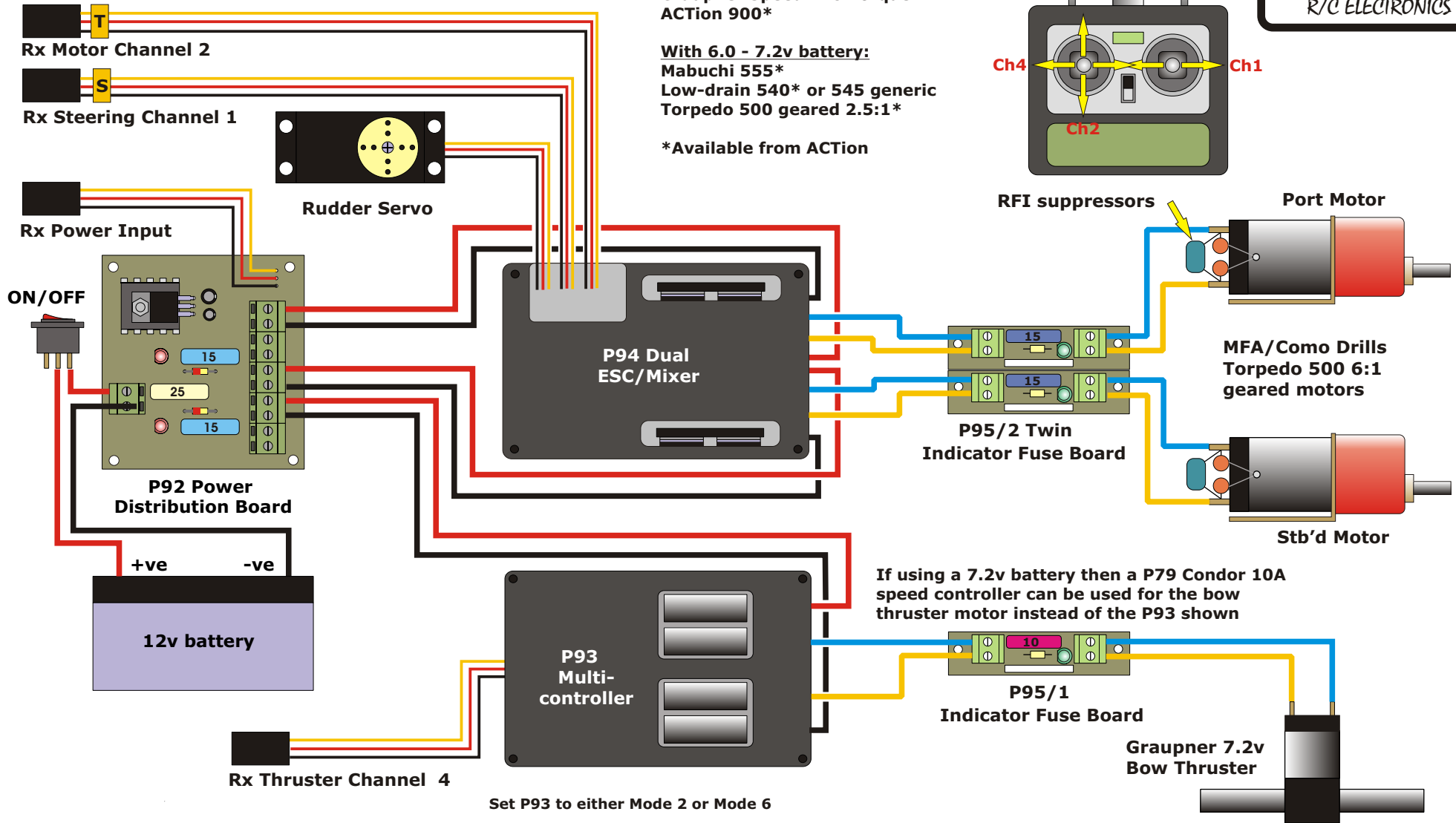

If using a 7.2v battery then a P79 Conдор 10A speed controller can be used for the bow thruster motor instead of the P93 shown

Set P93 to either Mode 2 or Mode 6