

# INSTALLATION OF ACTION ELECTRONICS IN Bait Boat for Mr Jon Nutter

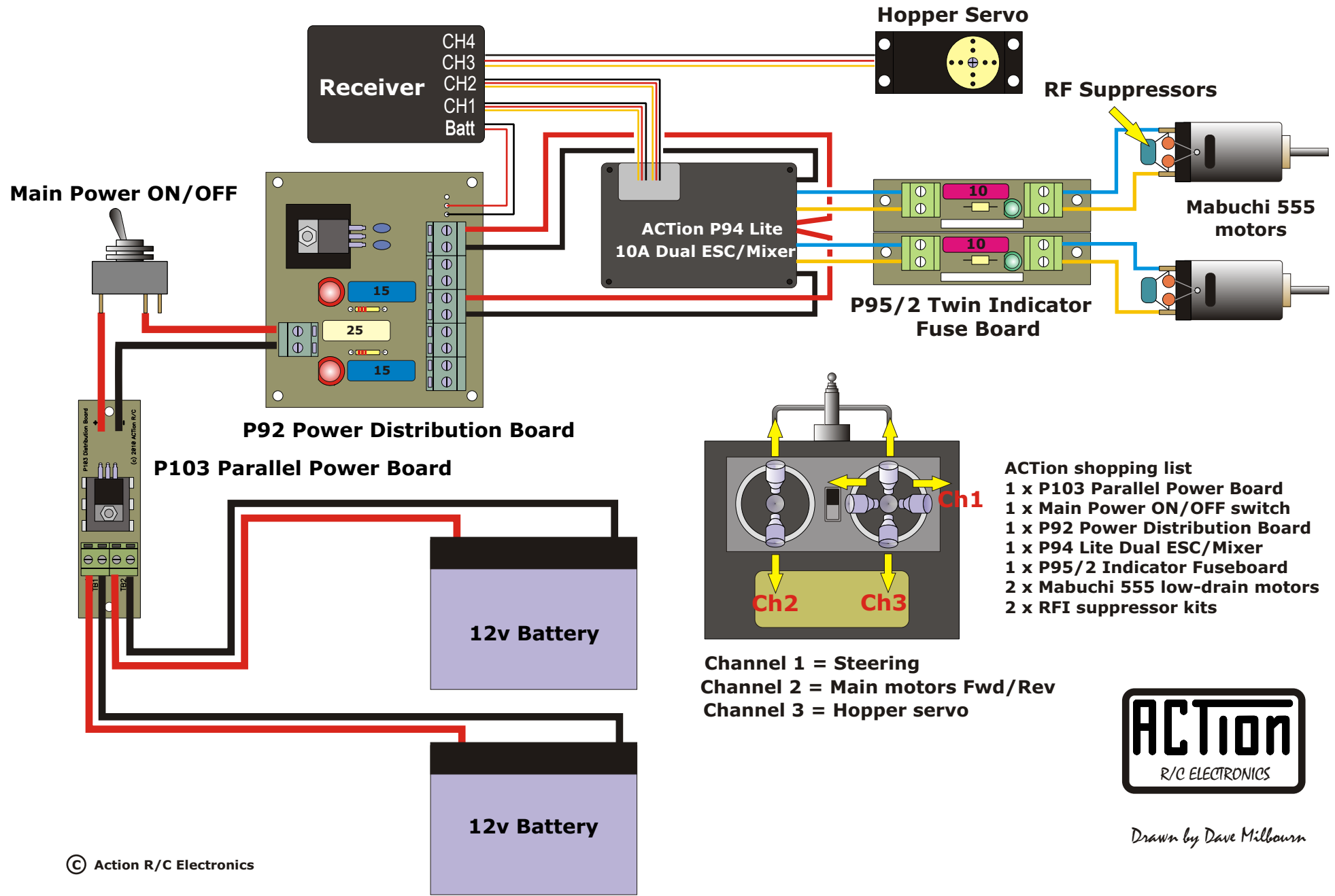

- Action shopping list**
- 1 x P103 Parallel Power Board
  - 1 x Main Power ON/OFF switch
  - 1 x P92 Power Distribution Board
  - 1 x P94 Lite Dual ESC/Mixer
  - 1 x P95/2 Indicator Fuseboard
  - 2 x Mabuchi 555 low-drain motors
  - 2 x RFI suppressor kits

Channel 1 = Steering  
 Channel 2 = Main motors Fwd/Rev  
 Channel 3 = Hopper servo



*Drawn by Dave Milbourn*